

## Emerald – fissure filling / clarity enhancement

Members of the Laboratory Manual Harmonisation Committee (LMHC) have standardised the nomenclature that they use to describe an emerald.

Any emerald that has no fissures or does not show indications of having undergone modification through the filling of fissures with oils, resins, wax or any other filler shall be described as,

- Species: **Natural beryl**
- Variety: **(Natural)<sup>1</sup> emerald**
- Comments: **None<sup>2</sup> or "no fissure filling"<sup>3</sup> or "no indications of clarity enhancement / modification"<sup>3</sup>**

Any emerald that shows indications of having undergone modification through the filling of fissures with near colourless oils, resins, wax or any other filler shall be described as,

- Species: **Natural beryl**
- Variety: **Emerald**
- Comments: **Fissure filling or "indications of clarity enhancement / modification",** (plus the appropriate quantification terminology), (plus the identification of the filler). See Table 1 for instructions concerning the use of the designated alpha numeric or text descriptions.

Status:	No fissures present in stone	No or insignificant filler in fissures <sup>3</sup>	Quantification and identification of filler in fissures		
			F1	F2	F3
Report Alpha numeric:					
Report Text:	None <sup>2</sup>	No / Insignificant fissure filling	Minor amount of oil / resin in fissures	Moderate amount of oil / resin in fissures	Significant amount of oil / resin in fissures
		<i>or</i>	<i>or</i>	<i>or</i>	<i>or</i>
		No / Insignificant indications of clarity enhancement / modification	Indications of minor clarity enhancement / modification	Indications of moderate clarity enhancement / modification	Indications of significant clarity enhancement / modification

**Table 1: Emerald, quantification and identification of filler in fissures**

**Note A:** Opaque residues of resins or oils that remain behind within fissures following "cleaning" or through deterioration shall not be reported upon within the context of this IS. However, an informative note shall be placed on reports if opaque residues of resins or oils remain behind within fissures of emeralds through deterioration, e.g., drying or incomplete cleaning. An example of such a note would be: '(oil/resin) residues present'

**Note B:** The presence of materials within fissures that occur naturally is not within the context of this IS and need not be declared.

**Note C:** Whether using the alpha numeric or text description, the report shall also illustrate the equivalent by appending the above table or this Information Sheet shall be referenced.

<sup>1</sup> Text in parenthesis is optional

<sup>2</sup> Only use if no fissures are observable

<sup>3</sup> Only use if fissures are observable

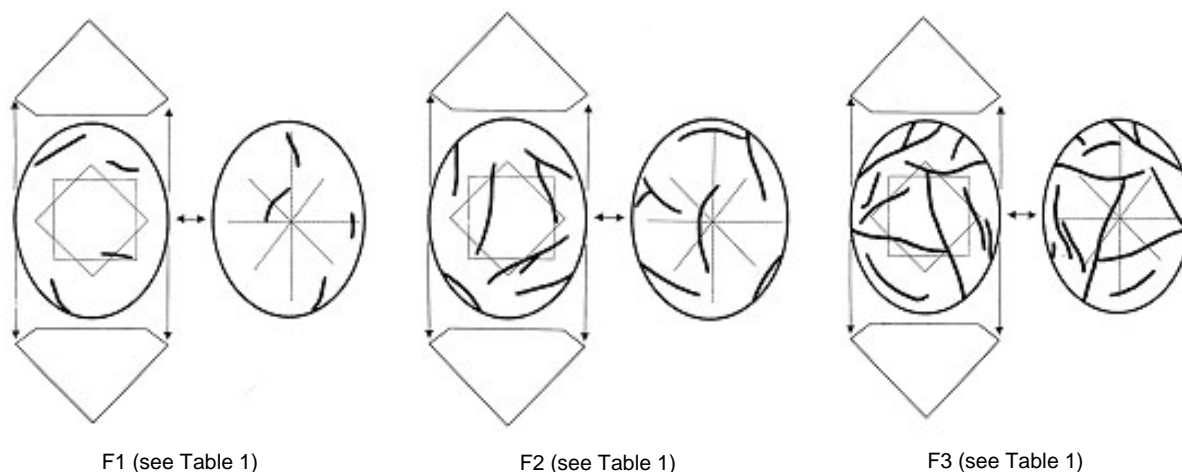

**Figure -1:** Illustrations for quantification of filler in fissures

Any emerald that shows indications of having undergone modification through the filling of wide fractures and/or cavities with near colourless resins or wax shall be described as,

- Species: **Natural beryl**
- Variety: **Emerald**
- Comments: **Cavity filling**  
(plus the appropriate quantification terminology), (plus the identification of the filler). See Table 2 for instructions concerning the use of the designated alpha numeric or text descriptions.

Condition →	Quantification and identification of filler in fracture(s) / cavity(ies)		
Report Alpha numeric →	C1	C2	C3
Report Text →	Minor amount of Resin / wax in cavities	Moderate amount of Resin / wax in cavities	Significant amount of Resin / wax in cavities

**Table 2:** Emerald, quantification and identification of filled wide fractures / cavities

**Note D:** Whether using the alpha numeric or text description, the report shall also illustrate the equivalent by appending the above table or this Information Sheet shall be referenced.

**Note E:** The presence of material within fractures that has occurred naturally is not within the context of this IS and need not be declared.

**Note F:** Durability/stability: oil/resin fillers may be unstable at elevated temperatures and to chemical agents. Special care shall be taken when repairing jewellery items set with oil / resin filled emerald. The unmounting of such stones prior to jewellery repair is recommended.

Any emerald that shows evidence of having fissures/fractures filled with coloured agents<sup>4</sup> that have an effect on the colour shall be described as,

- Species: **Natural beryl**
- Variety: **Emerald**
- Comments: **Coloured filler in fissures/fractures or “indications of clarity enhancement / modification by a coloured substance”** (plus the appropriate quantification terminology), (plus the identification of the filler). See Table 1 for instructions concerning the use of the designated alpha numeric or text descriptions.

---

Any beryl other than emerald that shows indications of having fissures/fractures filled with coloured agents shall be described as,

- Species: **Natural beryl**
- Variety: **(no variety)**
- Comments: **Dyed**

---

<sup>4</sup> This clause does not include the presence of polishing compounds in fissures.

© 2007 Laboratory Manual Harmonisation Committee. This document may be freely copied and distributed so long as it is reproduced in its entirety, complete with this copyright statement. Any other reproduction, translation or abstracting is prohibited without the express written consent of the Laboratory Manual Harmonisation Committee.